

34 mm Dome Tweeter

D3404/552000

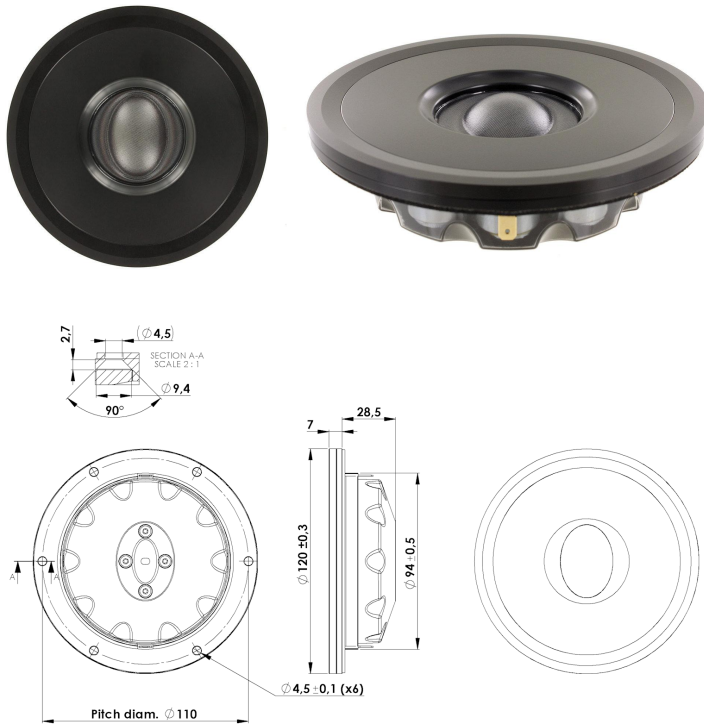

T-S Parameters:

Resonance frequency [fs]	475 Hz
Mechanical Q factor [Qms]	5.25
Electrical Q factor [Qes]	0.63
Total Q factor [Qts]	0.57
Force factor [Bl]	2.8 Tm
Mechanical resistance [Rms]	0.32 kg/s
Moving mass [Mms]	0.57 g
Compliance [Cms]	0.20 mm/N
Effective diaph. diameter [D]	~38 mm
Effective piston area [Sd]	11.4 cm ²
Equivalent volume [Vas]	0.04 l
Sensitivity (2,83V/1m)	97 dB

Mechanical Data:

Voice coil diameter	28/39 mm
Voice coil height	2.5 mm
Voice coil layers	2
Gap height	3 mm
Linear excursion	± 0.25 mm
Max mech. excursion	± 2 mm
Unit weight	0.75 kg
Cabinet Displacement Volume	0.13 l

Electrical Data:

Nominal impedance [Zn]	4 Ω
Minimum impedance [Zmin]	4.0 Ω
Maximum impedance [Zo]	30 Ω
DC resistance [Re]	3 Ω
Voice coil inductance [Le]	0.01 mH

Key Features:

- Elliptic voice coil
- AirCirc optimized magnetsystem
- Low mechanical losses
- Exceptionally low distortion
- High sensitivity (SPL)
- Flexible optics with replaceable decor ring

Recommendations (please see Tech Note):

- Operating frequency range: 2500-20000 Hz
- Cabinet volume - closed box: N.a.
- Cabinet volume - vented box: N.a.

Power Handling:

- 100h RMS noise test (IEC 18.4) 180 W
- Long-term max power (IEC 18.2) 300 W
- X-over: 2. order HP Butterworth, 2.5 kHz

